Wireless Temperature and Humidity Sensor

Wireless Temperature and Humidity Sensor R711 Data Sheet

Wireless Sensor Network Based on LoRa Technology

 LoRa Alliance Certified™



R711

Copyright©Netvox Technology Co., Ltd.

This document contains proprietary technical information which is the property of NETVOX Technology. It shall be maintained in strict confidence and shall not be disclosed to other parties, in whole or in part, without written permission of NETVOX Technology.

The specifications are subject to change without prior notice.

Wireless Temperature and Humidity Sensor

General Description

NETVOX Wireless Sensor R711 is capable to measure temperature and humidity of the indoor air.

Principle of Operation

Netvox R711, mainly used to detect the temperature and humidity of the indoor air, which through the wireless network communication module to collect the data sent to other devices displayed.

Thanks to small sizes, they can be installed everywhere. They are wireless so they take up minimal floor space. The transmission is direct to a central center that can be programmed to trigger an alarm system. Thanks to innovation, these wireless sensors are more reliable and precise and they can detect several applications.

Example Applications

- Warehouse emperature and humidity monitoring
- Summer/winter (vacation) property monitoring
- HVAC system monitoring to detect failures or heating / cooling issues
- Art gallery temperature monitoring
- Heat remediation of bed bugs (extermination)
- Server room temperature and humidity monitoring
- Greenhouse temperature and humidity monitoring
- Art gallery and museum environment monitoring

Features of NETVOX Sensors

- Wireless range of 10 km *1
 - LoRaWAN™ Class A compatible
 - Frequency Hopping Spread Spectrum (FHSS)
 - Improved interference immunity
 - Improved power management for longer battery life
 - Encrypt-RF™ Security (Diffie-Hellman Key Exchange + AES-128 CBC for sensor data messages)
 - Battery Life*2:
 - 5 years
 - (Conditions: ambient temperature 25 °C, 60 min heartbeats, txpower = 20dBm, LoRa spreading factor SF = 10)
 - Over-the-air updates (future)
 - Third-Party online wireless sensor monitoring and notification system to configure sensors, view data and set alerts via SMS text and email (optional)
 - Available third-party platform: Actility/ThingPark, TTN, MyDevices/Cayenne
- *1. Actual range may vary depending on environment.
*2. Battery life is determined by sensor reporting frequency and other variables

Wireless Temperature and Humidity Sensor

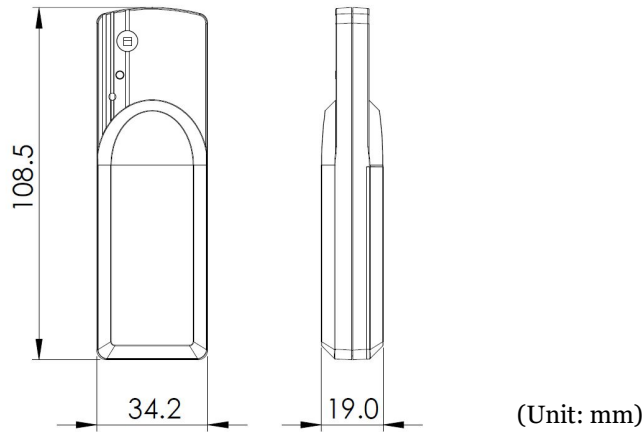
Technical Specifications

Electric

Input power	2 x 1.5V AA batteries
Operating power	DC 2.4V~3V
Standby current	12uA/3V
Transmitting current (max)	120mA/3V
Receiving current (max)	11mA/3V
Battery Voltage Measurement	±0.1V

Frequency

TX Power	19dBm±1dBm
Rx Sensitivity	-136dBm (LoRa, Spreading Factor=12, Bit Rate=293bps) -121dBm (FSK,Frequency deviation=5kHz, Bit Rate=1.2kbps)
Antenna Type	Build-in antenna
Communication Range	Up to 10 km, the actual transmission distance depends on the environment.
Data Transfer Rate	0.3kbps~50kbps
Spread Technique	LoRa/FSK
Available Frequency	EU863-870, US902-928, AU915-928, KR920-923, AS923, CN470-510 Configured before shipment

Wireless Temperature and Humidity Sensor

Physical

Dimension	L:112mm*W:34mm*H:17mm
Weight	83.8g
Operating Humidity	<90%RH
Operating Temperature	-20°C - 55°C
Storage Temperature	-40°C — 85°C
Temperature Measurement Range	-20°C — 55°C
Temperature Measurement Accuracy	±0.5°C @25°C Max. +/-0.8°C@ -20°C~55°C
Humidity Measurement Range	10%RH — 90%RH
Humidity Measurement Accuracy	±4%RH @25°C

Contact:**NETVOX TECHNOLOGY CO., LTD.****TEL: 886-6-2617641****FAX: 886-6-2656120****E-mail: sales@netvox.com.tw****WEB: www.netvox.com.tw****NETVOX TECHNOLOGY CO., LTD (XIAMEN)****TEL: 86-592-5717188****FAX: 86-592-5717180****E-mail: dyx@netvox.com.cn****WEB: www.netvox.com.cn**